

VEVOR[®]

TOUGH TOOLS, HALF PRICE

Technical Support and E-Warranty Certificate www.vevor.com/support

HITCH CARGO CARRIER

USER'S MANUAL

MODEL: CW03

We continue to be committed to provide you tools with competitive price.

"Save Half", "Half Price" or any other similar expressions used by us only represents an estimate of savings you might benefit from buying certain tools with us compared to the major top brands and does not necessarily mean to cover all categories of tools offered by us. You are kindly reminded to verify carefully when you are placing an order with us if you are actually saving half in comparison with the top major brands.

Model: CW03

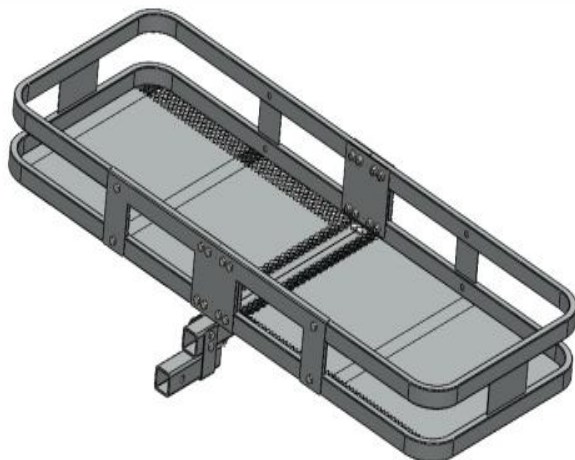

NEED HELP? CONTACT US!

Have product questions? Need technical support? Please feel free to contact us:

✉ CustomerService@vevor.com

This is the original instruction, please read all manual instructions carefully before operating. VEVOR reserves a clear interpretation of our user manual. The appearance of the product shall be subject to the product you received. Please forgive us that we won't inform you again if there are any technology or software updates on our product.



Safety & Warning

- Read and understand this entire manual before assembling, installing, operating, or servicing this product. Failure to follow these warnings and instructions can cause death, personal injury or damage to valuable property.
- Adhere to all Department of Transportation (D.O.T.) requirements when using this product. Use ropes and tie downs (not included) to securely hold all cargo in place.
- For the vehicle that will support the Cargo Carrier, read all pertinent vehicle instructions and warnings provided in the owner's manual. Make sure the vehicle's engine is OFF, with parking brake set, before loading or unloading the Cargo Carrier.
- This Cargo Carrier must be attached to a 2"x2" Class III or Class IV hitch receiver. The hitch must be properly installed by a qualified service technician and be certified to support the weight of this Cargo Carrier and its contents.
- This Cargo Carrier is designed to haul firewood, coolers and other similar loads. Do not modify the Carrier and do not use this product for purposes that it was not designed for.
- Do not overload the Cargo Carrier. Never exceed the maximum weight capacity.
- When assembly is complete, check and test all vehicle systems including lights and brakes; make sure no damage occurred during product installation.
- Frequently check the condition of the Cargo Carrier and the vehicle's hitch receiver. Make sure all components are in good condition. If the Cargo Carrier or hitch receiver become damaged through accident, or if any weld damage is noted, the product should be replaced. Check to make sure that all hardware is tightly secured in place. Keep the Cargo Carrier clean.
- Use common sense when working. Stay alert and concentrate when setting up and using the Cargo Carrier. Never work while under the influence of alcohol, drugs or medications.

- While assembling and using the Cargo Carrier keep work area clean and well lighted. Keep spectators and children out of the work area.
- Dress appropriately. Never wear loose fitting clothing or jewelry when working. Contain long hair, and keep hair, clothing and gloves away from moving parts.
- Be aware of the danger of "dynamic loading". This situation arises when a load is dropped onto the Carrier, resulting in a short term excessive load. Dynamic loading can result in damage and failure of the Carrier and/or hitch receiver, and personal injury to the person loading the Carrier.
- Never load people or animals into the Cargo Carrier.
- Weight inside the Cargo Carrier should be evenly distributed, with heavier items positioned towards the center of the Carrier.
- Note the position of the vehicle's exhaust pipes before setting up the Cargo Carrier. Make sure exhaust pipes are not in close proximity of the Cargo Carrier; flammable goods in the Cargo Carrier could catch on fire due to heat from the exhaust. If this risk exists on your vehicle, do not use the Cargo Carrier.
- Do not ride in vehicle being loaded or unloaded. Load and unload vehicle slowly, according to manual instructions.

Specifications

Model Series	CW03
Maximum Load Capacity (lbs)	500
For Use With	2" x 2" Class III and IV Hitch Receivers
Cargo Basket Dimensions (mm)	1524×610×152
Hitch Pin	5/8" Diameter with Cotter Pin
Gross Weight(kg)	29.4
MEAS(mm)	880×670×175

Package Contents

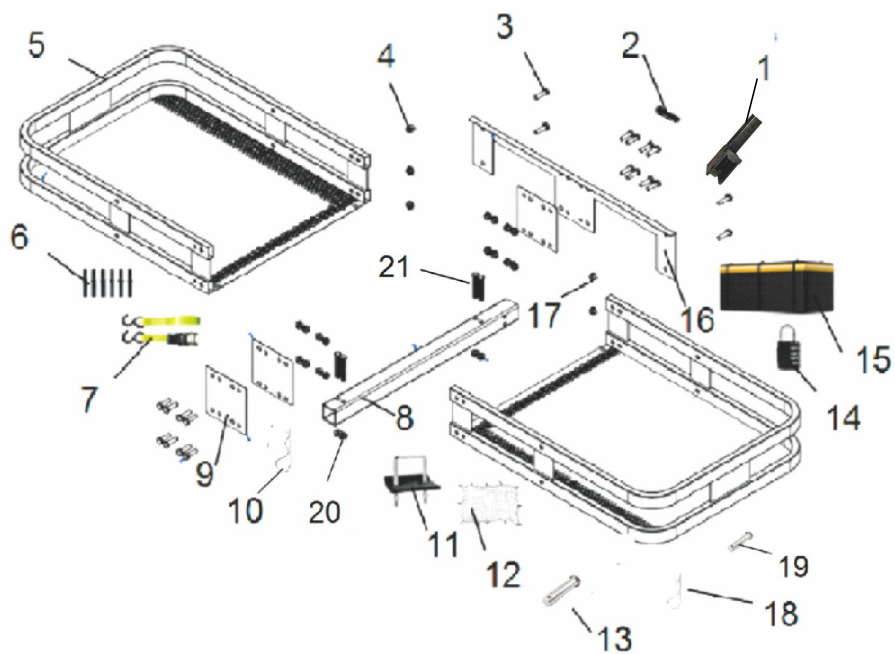

Part	Description	Qty
1	Rotating Seat	1
2	Bolt M10×75	1
3	Bolt M10×40	20
4	Washer	25
5	Frame	2
6	Bag Buckle Strap	6
7	Ratchet Belt	2
8	Support Rod	1
9	Small Connecting Plate	3
10	R pin φ4.0	1
11	Hook Stabilizer	1
12	Cargo Network	1
13	Rotary Bolt φ16*90	1
14	Combination Lock	1
15	Cargo Package	1
16	Big Connecting Plate	1
17	Nut M10	25
18	R pin φ2.0	1
19	Rotary Bolt φ10*75	1
20	Nut M8	2
21	Bolt M10×70	4

Installation Guide:

- A. Flip the two frame(5) over,And then attach the support rod (8) to the two framer with Bolt (21),Washers (4) and Nuts (17).Attach the small connecting plate(9) and the big connecting plate(16) to the frame component with Bolt (3),Washers (4) and Nuts (17).
- B. Attach the rotating seat(1) to the support rod (8) with the bolt (2), rotary bolt(19),R pin(18),washers (4) and nut (17) .
- C. To place the cargo carrier on the vehicle's hitch receiver:
 - a.With a helper, lift the empty cargo carrier and insert rotating seat(1) into the vehicle's hitch receiver.
 - b.Align the holes on rotating seat(1) and vehicle's hitch receiver,and then insert the rotary bolt(13) to the holes ,insert the R-pin(10) to the holes of rotary bolt(13) for last.
- D. Make sure all hardware is securely tightened.
- E. Load the cargo carrier as needed. Use ropes and tie downs to securely hold all cargo in place.
- F. When there is no cargo in the cargo frame, you can pull out the rotary bolt(19),and flip the entire cargo frame 90 degrees,and insert rotary bolt(19) to up holes of rotating seat(1),insert the R-pin(18) to the holes of rotary bolt(19) for last.

VEVOR[®]

TOUGH TOOLS, HALF PRICE

Support and E-Warranty Certificate

<https://www.vevor.com/support>

Made In China